

Attach bracket to Ascent with 2 M5 X 12 screws as shown in Figure 3.

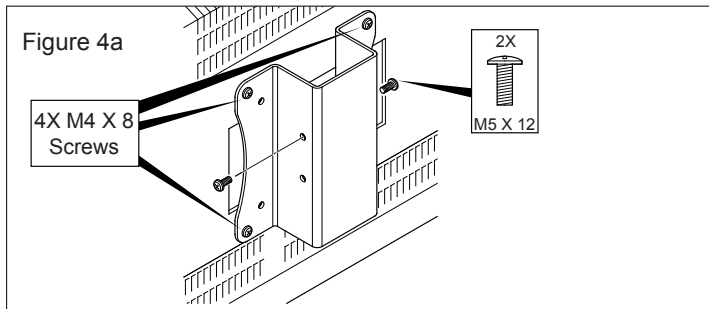

Figure 4a

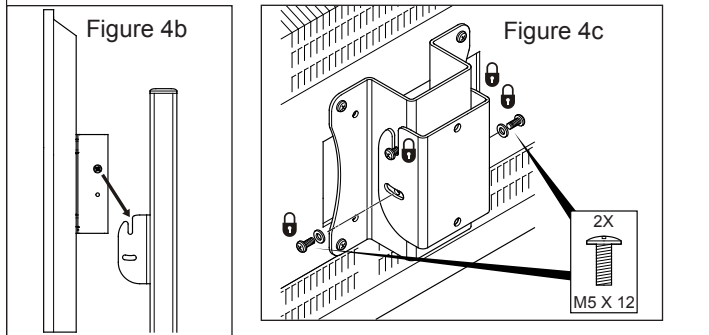

Figure 4b

Figure 4c

Attach bracket to screen with four M4 X 8 screws. Insert two M5 X 12 screws into the bracket, one on each side (Figure 4A). The M5 X 12 screws support the screen by resting in the slots on the lift bracket (Figure 4B). Insert two M5 X 12 screws into the slotted holes, adjust the tilt angle as desired and secure the bracket position (Figure 4C). This bracket allows screens to vertically tilt up to 18°.

Counterbalance Weight Installation

Weight plates are installed to counterbalance the weight of the television/screen.

The Ascent CBLIFT-0019 comes with one weight pack, which includes 10 units @ 3.88 oz. [110 gm] each, totalling 2.43 lbs. [1.1 kgs.]. See chart to determine the potential number of weight packs required for your specific installation. Additional optional weight packs may be ordered separately.

If more than two weight packs are required, order the Weight Extension Plate Kit (P/N 2990-9775-BE).

Important: Inadequate weight may cause the unit to lift too quickly. Too much weight will override the spring-action movement.

Note: Bracket and extension plate weights are accounted for within the calculations in the chart.

Screen Weight	No Bracket	Fixed Bracket	Tilt Bracket
Min. Weight*	6.61 lbs. 3kgs.	5.73 lbs. 2.6 kgs.	5.51 lbs. 2.5kgs.
Additional Weight Packs Recommended			
5.51–7.72 lbs. [2.5–3.5 kgs.]	3	3	3
7.72–8.82 lbs. [3.5–4.0 kgs.]	3	3	2
8.82–11.0 lbs. [4.0–5.0 kgs.]	2	2	2
11.0–12.12 lbs. [5.0–5.5 kgs.]	1	1	1
12.12–13.2 lbs. [5.5–6.0 kgs.]	1	1	0
13.2–14.5 lbs. [6.0–6.6 kgs.]	0	0	0
Maximum Weight** 14.5 lbs. /6.6 kgs.			

* Weights less than this may not provide enough counterbalance for the mechanism and could cause rapid movement that may damage the unit or the installed item.

** Weights above this may override the spring-action on the lift, requiring manual movement.

Installing Weights

Remove nuts (Figure 1), add weight plates, and secure nuts (Figure 2). Fully close the Ascent and then press to release to test the counterbalancing. Add or remove one plate at a time to test movement. Adding more than two weight packs requires the Weight Extension Plate Kit. To install the extension plate, remove nuts and weights, install extension plates, replace weights, and secure (Figure 3). Add weights as required and test after each addition.

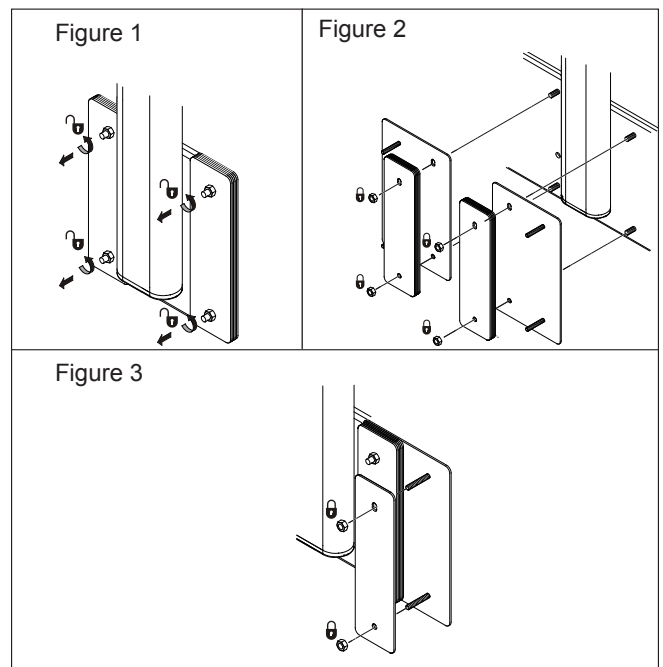

Optional Kits

Additional Weight Pack (3.88 oz. x10 Plates): P/N 2990-9774-BE

Weight Extension Plate Kit: P/N 2990-9775-BE
(required if more than two weights packs used)

VESA Tilt Bracket (fasteners included): P/N 2990-9776-BE

VESA Fixed Bracket Kit (fasteners included): P/N 2990-9777-BE

Specifications

Optional kits: Cold rolled steel

RoHS Compliant

NOTE: Specifications, materials, prices, terms, and delivery are subject to change without notice.

Accuride[®]

ACCURIDE INTERNATIONAL INC.

12311 Shoemaker Avenue
Santa Fe Springs, CA 90670

TEL (562) 903-0200

FAX (562) 903-0208

www accuride.com

Manufacturing, Engineering, and Sales

United States • Germany • Japan • Mexico • United Kingdom • China