

Heavy Duty Bi-Fold Door Set

Wing Line Grant 1260

up to 175 lbs/door (80 kg/door)

for door thickness 1" (25.4 mm) minimum, top mount, adjustable

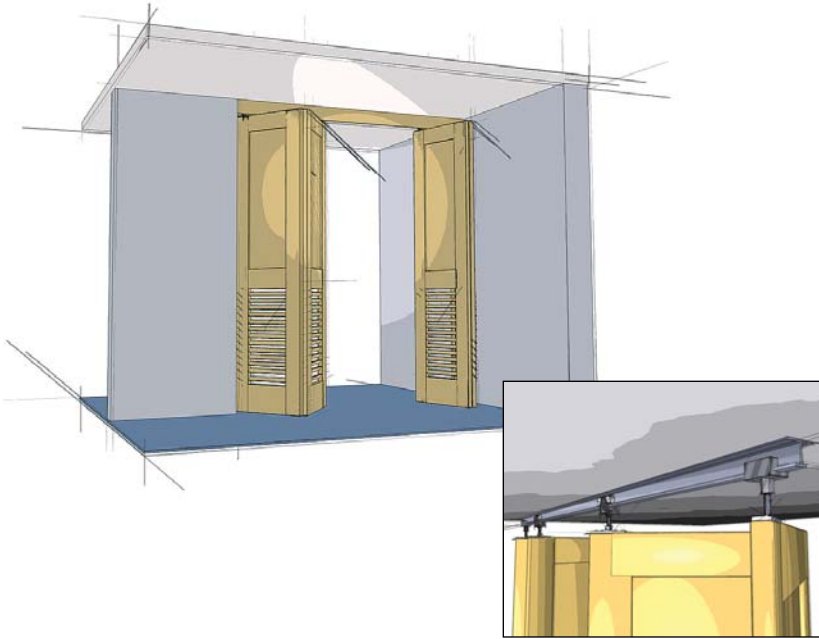

Wing Line Grant 1260

A heavy duty, top hung folding door system. The Wing Line Grant 1260 system supports most heavy duty residential and commercial grade bi-fold applications.

- For door panels 1" [25.4 mm] minimum and up
- For doors weighing up to 175 lbs [80 kg] per panel
- 4 wheel carrier with precision ball bearing wheels for quiet, effortless operation.
- Aluminum track up to 16' [4800 mm]
- Pre-drilled track for easy installation
- One-way or bi-parting sets available
- Conforms to ANSI/BHMA standards
- Made in USA

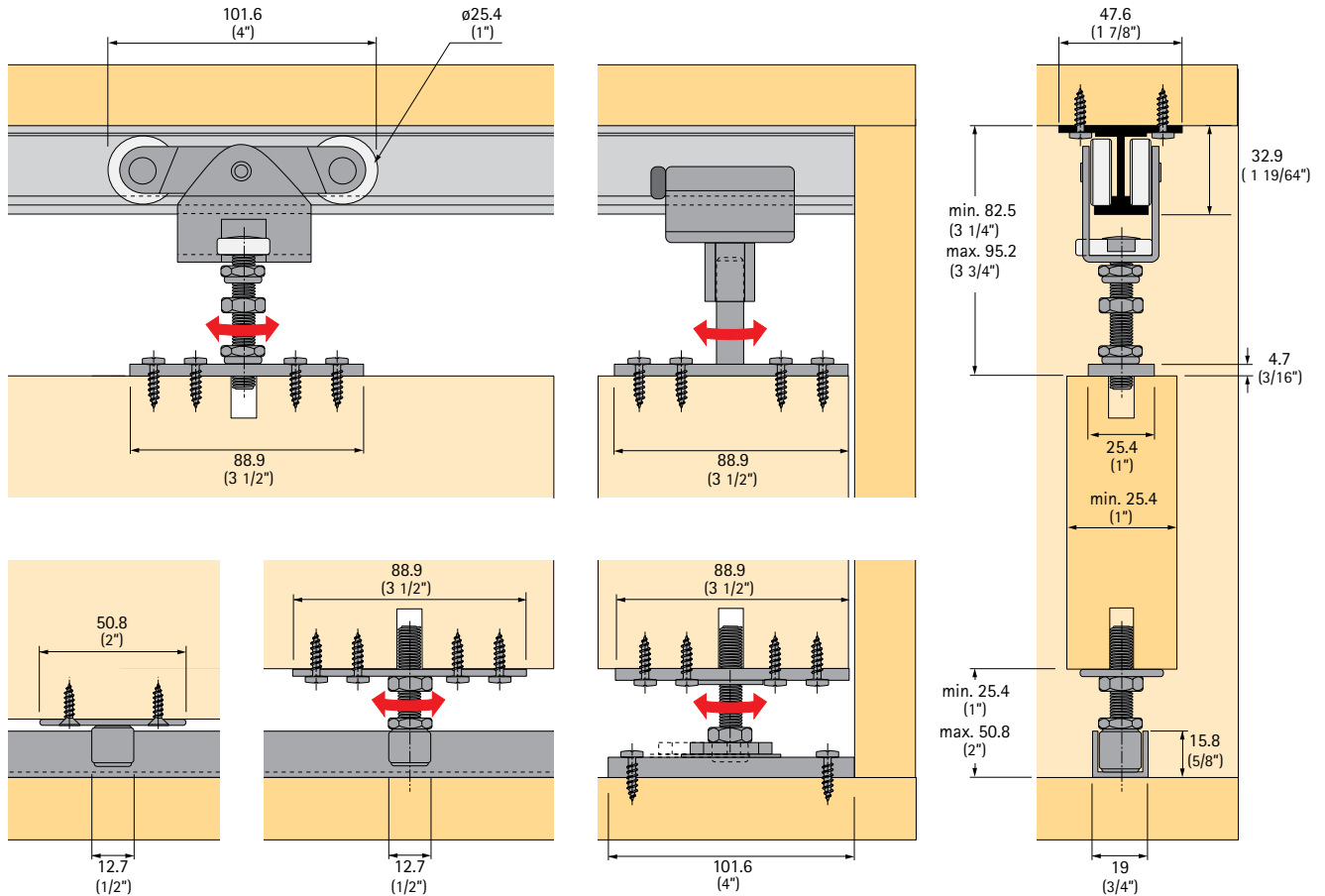

Specifications:

- Mounting: Top
- Adjustment: 1/2" (12.7 mm) vertical
- Door thickness: 1" (25.4 mm) min.
- Headroom: 3 1/4" (82.5 mm) min., 3 3/4" (95.2 mm) max.
- Application: Bi-fold

Wing Line Grant 1260 door hardware is available in four purchasing options

Option I

Complete package includes: track, hardware set, and all screws

Wing Line Grant 1262 two-door (one way) set Hardware and track

Packing includes:
1 track 1201
1 hardware set 1260

Length	Order no.	PU
4' (1200 mm)	113 328 5	10 sets
6' (1800 mm)	113 328 6	10 sets
8' (2400 mm)	113 328 7	10 sets

For longer track application order hardware set and track separately

Wing Line Grant 1264 four-door (two doors each way) set Hardware and track

Packing includes:
1 track 1201
2 hardware sets 1260

Length	Order no.	PU
4' (1200 mm)	113 328 8	10 sets
5' (1500 mm)	113 328 9	10 sets
6' (1800 mm)	113 329 0	10 sets
8' (2400 mm)	113 329 1	10 sets
10' (3000 mm)	113 329 2	10 sets
12' (3600 mm)	113 329 3	10 sets
16' (4800 mm)	113 329 4	10 sets

For longer track application order hardware set and track separately

Option II

Track only

Single track 1201

Aluminum extruded, pre-drilled holes



Length	Order no.	PU
4' (1200 mm)	050 121	5
5' (1500 mm)	050 122	5
6' (1800 mm)	050 123	5
8' (2400 mm)	050 124	5
10' (3000 mm)	050 125	5
12' (3600 mm)	050 126	5
16' (4800 mm)	050 127	5

Screws not included - recommend #12 Pan Head

Option III

Hardware set only (without track)

Wing Line Grant 1260 hardware sets

Hardware set 1260 for two door opening

- Hardware set includes:
- 1 ball bearing carrier with pendant bolt and top plate 1205
 - 1 floor pivot bolt assembly 1223
 - 1 bottom pivot pin plate 1224
 - 1 bottom pivot plate assembly 1234
 - 1 top pivot clamp assembly 1255
 - 1 top pivot post assembly 1269 screws



Article	Order no.	PU
Hardware set 1260	113 328 4	1 set

Hardware set 1225

Hardware kit to convert 1230 to folding door

- Hardware set includes:
- 1 floor pivot bolt assy 1223
 - 1 bottom pivot pin plate 1224
 - 1 bottom pivot plate assy 1234
 - 1 top pivot clamp assy 1255
 - 1 top pivot plate assy 1269 screws
 - installation instructions 1260

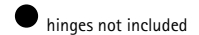

Article	Order no.	PU
Hardware set 1225	050 151	1 set

Option IV

Separate components

Wing Line Grant 1260 components

Carrier 1205

Steel, four wheels with precision ball bearings, includes pendant bolt and top plate

Screws included



Finish	Order no.	PU
zinc-plated	113 327 1	10

Heavy Duty Bi-Fold Door Set

Wing Line Grant 1260

up to 175 lbs/door (80 kg/door)

for door thickness 1" (25.4 mm) minimum, top mount, adjustable



Made in USA

Top pivot clamp assembly 1255

Aluminum extruded
with rubber bumper



Article	Order no.	PU
Top pivot clamp assembly 1255	050 161	10

Top pivot post assembly 1269

Steel



Finish	Order no.	PU
zinc-plated	050 173	10

Bottom pivot pin plate 1224

Steel



Finish	Order no.	PU
zinc-plated	050 150	10

Floor pivot bolt assembly 1223

Steel



Finish	Order no.	PU
zinc-plated	050 149	10

Bottom pivot plate assembly 1234

Steel



Finish	Order no.	PU
zinc-plated	050 160	10

Optional parts (not included in set)

Guide channel 1222

Aluminum extruded

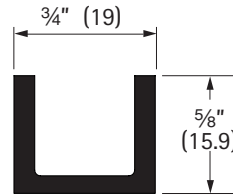

Length	Order no.	PU
4' (1200 mm)	050 142	5
5' (1500 mm)	050 143	5
6' (1800 mm)	050 144	5
8' (2400 mm)	050 145	5
10' (3000 mm)	050 146	5
12' (3600 mm)	050 147	5
16' (4800 mm)	050 148	5

Screws not included - recommend #6 Flat Head

Guide roller 1211

Steel, non adjustable

Screws included



Article	Order no.	PU
Guide roller 1211	050 138	20

Guide roller 1221

Steel, adjustable

Screws included



Article	Order no.	PU
Guide roller 1221	050 141	20